

C3TS Report 4 – Demonstration part (firefighter nozzle)

Tero Jokelainen

30.8.2018

This report describes whole 3D-printing process chain for firefighter nozzles. Process chain includes phases design, printing and post-processing. Material were selected to be 316L due to its usage and layer thickness for all prints were 30 μm . Function of the part is that it is connected to the tube where water has high pressure and nozzle sprays water. Device is pushed through the door and the sprayed water cools the room and the door temperature. Four different designs were tested and one of those was the reference part which is original design. Original part had already shape that it was able to metal 3D print. In the fig. 1 is shown reference part.



Fig. 1 Reference part.

Design

Design 1 (original)

Design 1 was the original part. There were no previous CAD-models or drawings for the part so it had to be sketched with CAD. Dimensions for the part were measured by slide gauge and pitch gauge. This means that there can be some variation between dimensions of the original part (reference) and 3D-printed original part (design 1). In the fig. 2 is showed pictures of the design 1.

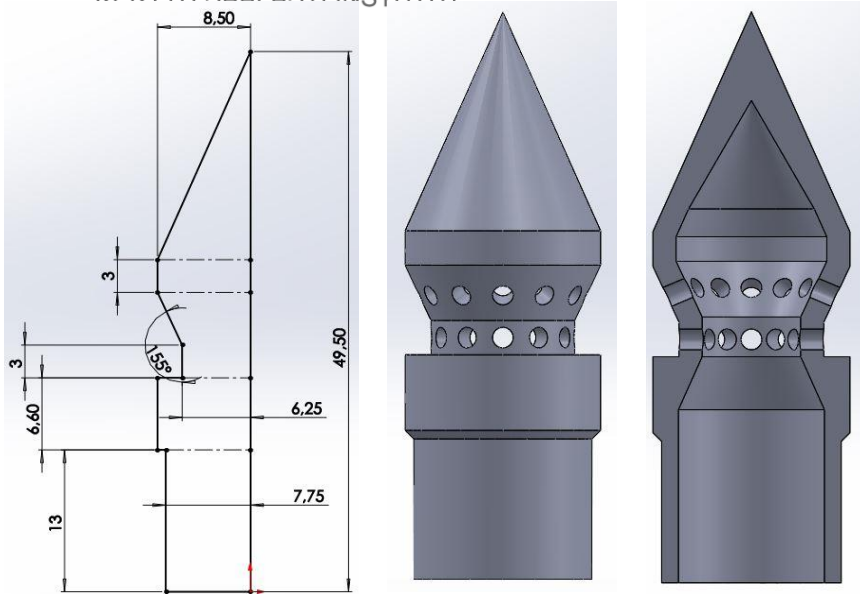

Fig. 2 Design 1; dimensions for the part (left), model (middle) and section view (right).

In fig.2 can be seen dimensions which were measured from the original part. Part included M15x1 thread which were not printed. There were left 0.5 mm machining tolerance. In this design there was two channels which had 12 holes in both rows.

Design 2

Design 2 was modified so that the diameter of the nozzle head was enlarged which made possible to place more holes to the structure. In this model there is two channels which include 14 holes in both rows. In fig.3 is shown pictures of design 2.

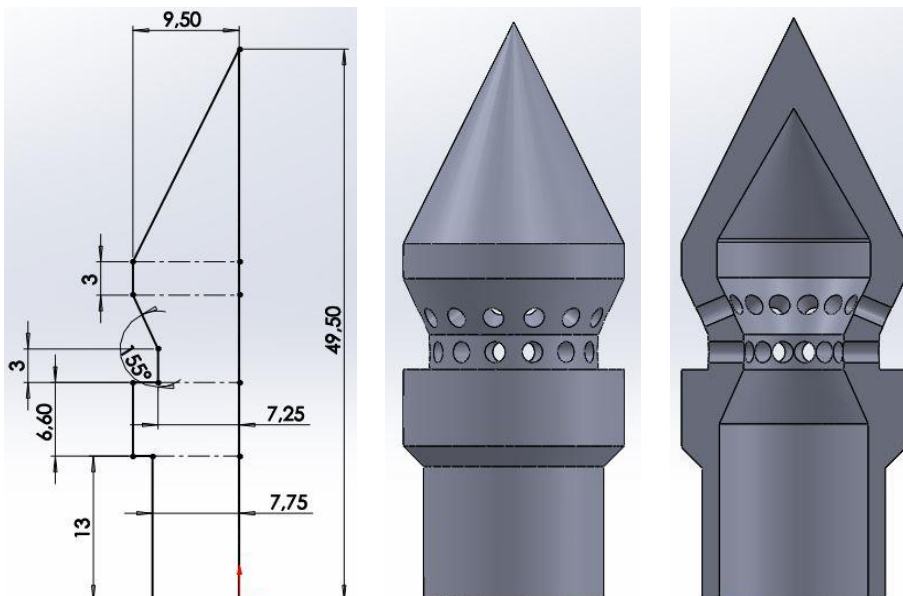

Fig. 3 Design 2; Dimensions for the part (left), model (middle) and sectioned view (right).

In the fig.3 can be seen that the diameter of nozzle head is 2 mm wider in design 2 compared to the design 1. Also design 2 has 14 holes in a row when design 1 has 12. Angle of the nozzle head is bigger in design 2. Other dimensions are the same than in design 1.

Design 3

Design 3 was modified so that there are three channels instead of two. Amount of the holes in a row are same than design 1. In the fig.4 is shown pictures of design 3. Base dimensions are the same than design 1 except the additional chamfer made for third channel.

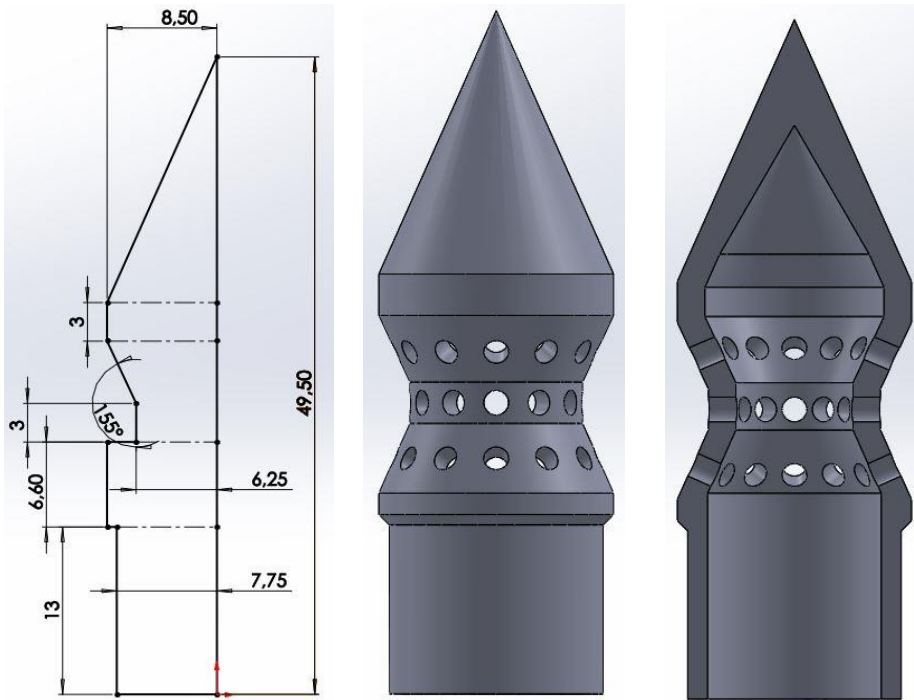

Fig. 4 Design 3; Dimensions for the part (left), model (middle) and sectioned view (right).

Design 4 is equal with design 3 except spiral channel is added in the model. (Fig 5.)

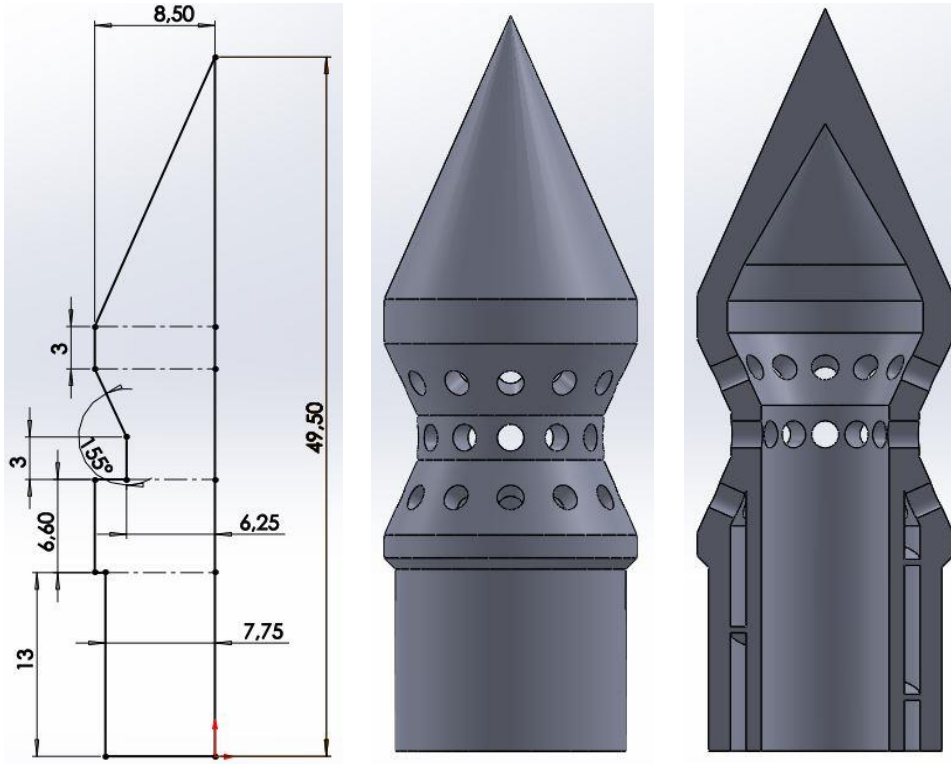

Fig. 5 Design 4; Dimensions for the part (left), model (middle) and sectioned view (right).

3D-printing

Orientation & Supports

Orientation for nozzles were vertical so that supports were only on the bottom of the part. Support structures were block type with 0.7 mm hatch distance. This part was a good example that how optimized can support structures be. This part could be possible to print also without any supports (directly on the platform). In this case height of the supports were 4 mm because manual part removal equipment was in use. Wire EDM would be a good tool if parts are printed directly on the platform. In the fig. 6 is shown supports for fireman nozzles. There can be seen supports marked with blue color (left) and support hatching (right). The volume of the part and supports were 3403 mm³ and 226 mm³, respectively. This means that the share of the supports in the total structure volume is slightly over 6 % which is a good number.

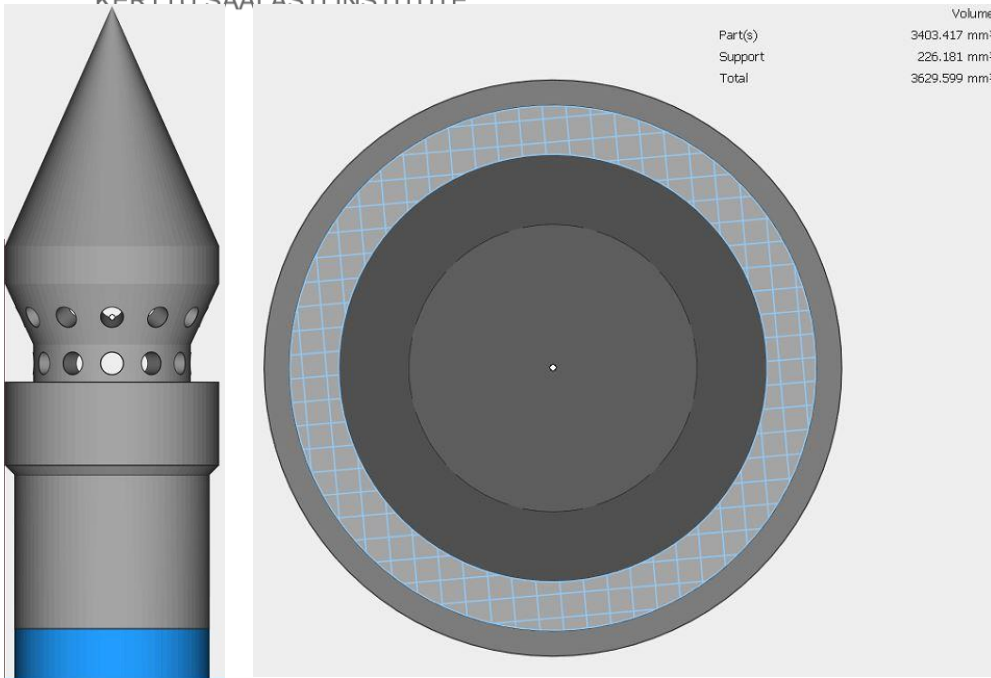

Fig. 6 Supports for the part; bottom image (right).

Printing parameters

Material were AISI 316L with 30 μm layer thickness. Main processing parameters are listed in table 1.

Table. 1 Main processing parameters

	Laser power [W]	Scanning speed [mm/s]	Hatch distance [mm]
Supports	200	875	-
Border	100	400	-
Volume hatch	200	800	0.12

Parameters for supports does not have hatch distance because support hatches are vectors which have the size of the laser spot. Same situation is with border. In the fig. 7 can be seen different spots of the one printing layer. Border parameters affects only to the outer lines of the part. Border parameters affects more to surface roughness of the part. Fill contour means the inner line of the part which is closing the hatching. Fill contour and border should melt together after scanning. Volume hatch means the inner structure of the part. Mechanical properties can be affected with volume hatch parameters. Hatch distance means the distance between two vectors.

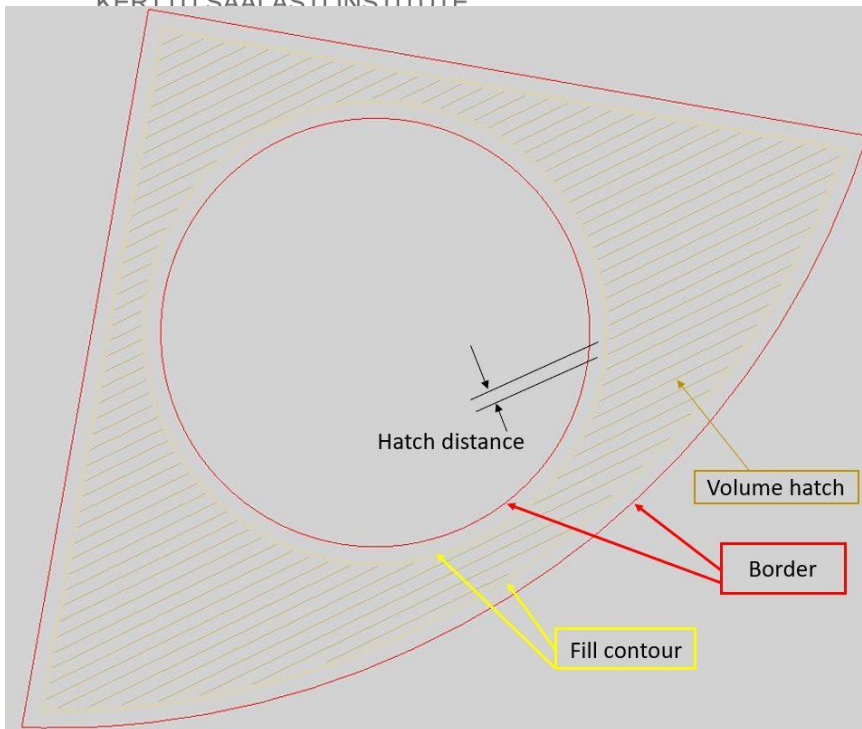

Fig. 7 Processing parameters; picture taken from one layer.

Printing time & cost

Printing simulation were done for small batch (200 pcs) to calculate scanning time. Scanning time is the most crucial thing for calculating costs for 3D-printed parts. In the fig. 8 is showed platform and how parts are placed on it as well as printed parts on the platform. There can be seen that original version (design 1) is b, design 2 is d, design 3 is a and design 4 is c.

Total volume of the parts and supports were 725919 mm^3 which included parts volume (680683 mm^3) and volume of the supports (45236 mm^3). Material costs can be calculated with the help of these numbers. Scanning time for 200 pcs is 5 days and 13 hours (time estimate from the SLM280HL). This means that scanning time is 133 hours and when it is multiplied with machine costs for example 100 €/h, the scanning costs are 13300 €. Material costs are 573.5 € ($0.726 \text{ dm}^3 * 7.9 \text{ kg/dm}^3 * 100 \text{ €/kg}$). This means that total costs of printing process are 13873.5 € and cost per part is 69.4 €.

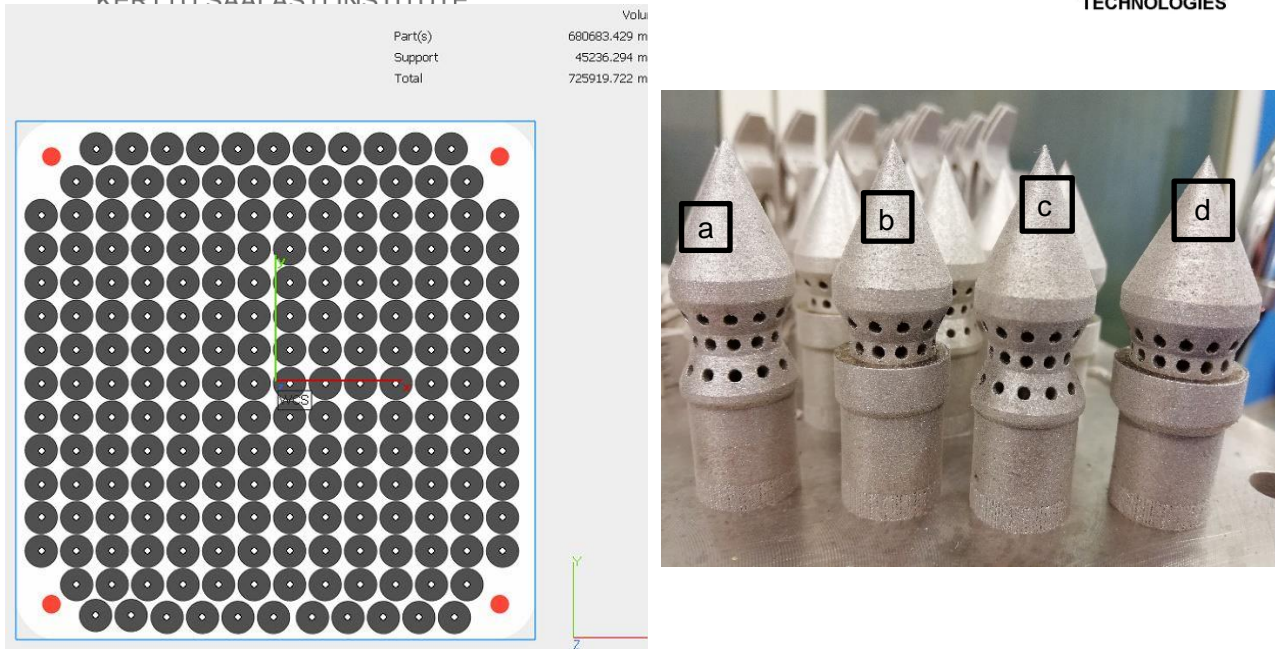

Fig. 8 200 pcs batch for fireman nozzles (left) and four different versions on the platform (right).

Post-processing

Post-processing included

- Heat-treatment for half of the parts
 - o 1 hour ramp to 600 °C
 - o 2 hours holding time in argon atmosphere
 - o cooling in air
- Removing the pieces from the table with manual cutting tool
- Removing rest of the supports with side cutters
- Finishing the nozzle head with file and sandpaper
- Turning cylinder to right size for the thread and making place for O-ring
- Making thread manually with threading set

Post-processing with these methods took about half an hour for each part. This mean that post processing cost is approximately 30 € per part (60 €/hour). But all post-processing phases were done manually. Costs could be lower if post-processing is made with NC-machines. In the fig. 9 is shown pictures of the post-processed parts.



Fig. 9 All designs post-processed.

Results and conclusions

- Part was able to print with small amount of supports
 - o Only slightly over 6 % was support structure of the total volume
- 4 different designs were done
 - o Practical test results will inform the functionality of the designs
- Time and cost estimation were done for 200 pcs
 - o 3D printing cost per part is 69.4 € (printing time and material)
 - o Post-processing was done manually and cost per part were about 30 €
 - o Total cost per part is about 100 €
 - o Costs could be lower if NC-machines are involved in post-processing phases